

The Force *Powered Subwoofer*

Owner's Manual

Contents:

Guarantee/Warranty	...2
Quick Setup	...4
Specifications	...5
Performance	...5
Installation	...7
Hookup	...11
Other System Considerations...	15
Avoiding Damage	...16
Troubleshooting	...17
Warranty Registration	...18



Audio Concepts, Inc.

901 So. 4th Street

La Crosse, WI 54601

Phone: (608) 784-4570 Fax: (608) 784-6367

URL: <http://www.audioc.com> Email: service@audioc.com

All Right Reserved 2002

Sound that Satisfies...

Audio Concepts, Inc.

Our Guarantee and Warranty

Satisfaction Guaranteed:

We're sure you're going to love your new Audio Concepts, Inc. (ACI) products! In the unlikely event that you are not satisfied, please contact us within **30 days** of receipt of your ACI products for a hassle-free return.

1. **Return Authorization:** Call us at (608) 784-4570 or email service@audioc.com, within 30 days of receipt of your ACI products for a return authorization number. Clearly mark the return authorization number on the outside of the box. Include a brief note stating your name, address and daytime telephone number, along with a short description why the products are being returned.
2. **Returning:** We request that you return the ACI products to us in their original packaging and include packaging materials, manuals, etc. Ship by the most economical means (preferably UPS) and insure the products for the invoice purchase price. The customer is responsible for return shipping.
Please note: ACI does not accept C.O.D. returns.
3. **Credit:** Upon receipt and inspection, we will issue a refund for the invoice purchase price and invoiced UPS Ground service only. Please note this return policy is in effect only if the ACI products are in new condition, in their original packaging, without drilled holes, disassembled or any other modifications.

Speaker Manufacture's Warranty:

For **five years** from receipt, Audio Concepts, Inc. will, at its option, repair or replace factory defective components. This warranty does not apply to products that have been abused, modified, or disassembled in any way. This warranty does not apply to products, which have been damaged in shipping. Audio Concepts, Inc. liability is limited only to the replacement of defective parts. No other liabilities or obligations are written or implied.

1. **Return Authorization:** Call us at (608) 784-4570 or email service@audioc.com for a return authorization number. Clearly mark the return authorization number on the outside of the box. Include a brief note stating your name, address and daytime telephone number, along with a short description why the products are being returned.
2. **Returning:** Carefully repack defective ACI merchandise. Ship by the most economical means (preferably UPS) and insure the products. The customer is responsible for return shipping.
Please note: ACI does not accept C.O.D. returns.
3. **Replacement:** Audio Concepts, Inc. will inspect and determine the cause of failure and will pay return shipping on the defective goods replaced or repaired.

The above stated guarantee and warranty applies only to assembled speaker models purchased directly from Audio Concepts, Inc. A different warranty and guarantee applies to purchasers of parts kits and DIY components.

Please ship any returns to the following address:

Audio Concepts, Inc., 901 So. 4th Street, La Crosse, WI 54601 (608) 784-4570

IMPORTANT NOTICE

All new speakers require a minimum of 60 hours break-in-time before they begin to sound the way they are supposed to. A speaker's performance improves significantly once broken in. It is critical that you have at least 60 hours on your speakers before you evaluate them. Don't worry if your speakers do not sound perfect the first time you play them. This is normal until they are broken in. If you are having difficulty getting enough hours on your speakers and your 30 day return privilege is getting near, call us. We will work with you. Please give us the courtesy of breaking the speakers in before you determine they don't sound right.

Many of our customers break their speakers in by:

- A) Leaving them on at moderate listening levels when they are not home.
- B) Leaving them on at moderate listening levels while they sleep.
- C) Running pink noise through them.

These methods are not convenient for everyone and we understand this. But please know that you are not giving yourself, your speakers or us a fair chance if you do not break them in before critical evaluation.

THANK YOU!

READ FIRST! QUICK SETUP

The flexibility of the Force allows it to be easily and quickly installed in virtually any audio system. By reading the following steps and referring to the diagrams in the owner's manual, you'll have your Force(s) up and running in no time.

- 1) Determine if you will need to use the *Speaker Level Converters* (two supplied). If your receiver, pre-amp or processor (source) has RCA subwoofer output(s) or pre-out, main-in, you will NOT use the *Speaker Level Converters*.
- 2) If you will be using the *Speaker Level Converters*, you will use both converters, connect as shown in the Force hookup section diagrams for using a receiver. Connect the *Speaker Level Converters* to the Force Inputs. Hook up your speaker cable from the same output terminals you are using for your main speakers. Connect the speaker cable and the *Speaker Level Converters*. Connect the same polarity as your main speakers, red to red, black to black. *Skip the following step and continue to Turn-On.*
- 3) If you are using direct RCA connections, you may have several hook-up options. *Try the simplest first.* If your source has subwoofer outputs try that first. Use a shielded RCA cable of sufficient length to connect the subwoofer output of your receiver/processor directly to the Theater input on the Force. Turn both crossover controls to 250Hz. If you don't have sub outputs you will use the pre-outs as shown in the Force hookup section. If you only have one set of pre-outs you will need to use a *Y Adapter* and RCA interconnect or jumper to connect to the main amp inputs. If you are using the optional *Passive High-Pass Filters* they insert into the main amp inputs (see below).

Turn-On

- Turn volume control (Input Level) on the Force(s) all the way down set both crossover controls (Lowpass Filters A & B) to about 100Hz, (250Hz if using Theater input).
- Turn volume control on source all the way down.
- Plug in and switch on the Force(s). There will be a slight thump, this is normal.
- Play some music with a consistent, clear bass line at a moderate level.
- Turn the Force volume level up slowly until it just fills in the bottom range.
- NOW, sit back and relax with some good music while reading the manual which will help you fine-tune the Force using level, crossover frequency, placement and phasing.

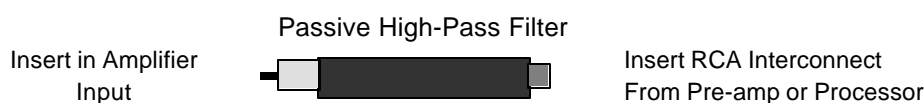
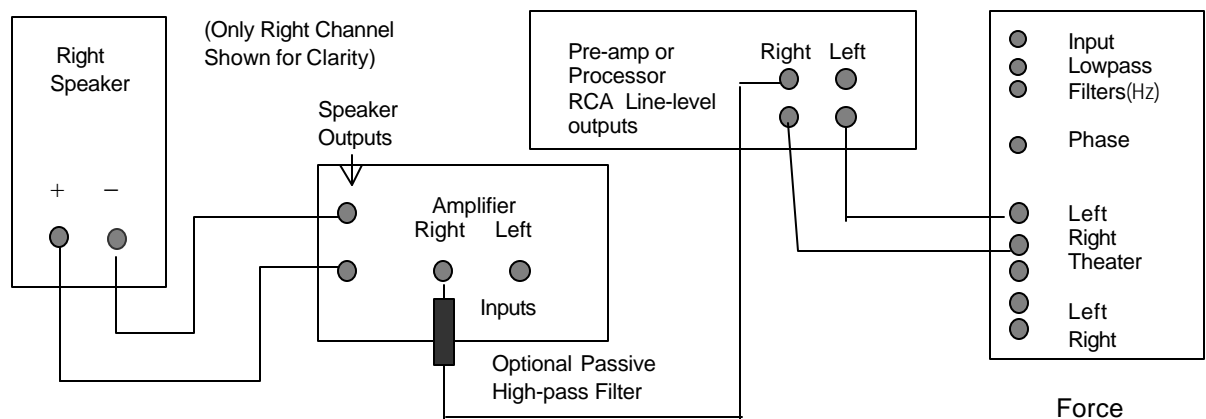

The *Force* Powered Subwoofer

Thank you for your order and congratulations on becoming the owner of an ACI speaker system. The Force powered subwoofer(s) will provide you with many years of listening pleasure!

ACI's Force is a compact, yet potent subwoofer. The Force is based on the subwoofer technology of our legendary Titan series. An extreme excursion 10" driver is powered by our proprietary amplification using special circuitry to essentially cut the required box volume in half!

Many subwoofers do a respectable job with explosions, shotguns, and crashes. The market is loaded with black boxes and tubes that beg to be "hidden". The Force is different. Compact, yet attractively built to compliment your fine furniture. The Force will rattle your china. More importantly, it will allow a seamless and completely transparent blend with your main speakers. Your sound stage will be enhanced, not degraded. Instruments like acoustic and electric bass, piano, and percussion will come through with vivid realism. The Titan II LE has earned a reputation of being one of the most musical subs available at any price. The Force continues this tradition of musical excellence in a smaller cabinet, at lower cost.

The internal enclosure is constructed of ¾" non-resonant high-density fiberboard with extensive internal bracing. The mounting for the downfiring woofer is 1.25" thick for additional resonance control and stability. Solid hardwood panels coated with multiple layers of clear or black lacquer grace the exterior and add additional damping. For even higher output levels, multiple Force units may be stacked.

Specifications

Frequency Response: 20-250Hz, ± 3 db, system Q < .6

Crossover: Dual adjustable Low-Pass: 35-250 12db/octave filters for 24db/octave total

High Pass Outputs: Second order, 12db/octave, filters set at 100Hz for left & right output. Line-level, RCA outputs

Sensitivity: Adjustable

Dimensions: 13.5" tall, 16.75" wide and 12.5" deep

Special Circuitry: Protection Circuitry, Woofer Behavior Control, Theater-Direct Input

Woofer: (downward firing) Proprietary 10", ultra long throw woofer

Rec. RMS Power: Built in amp delivers 250 watts RMS < .5% THD distortion.

Performance

The electronics of the *Force* performs the following functions:

- Gain is controlled at the INPUT LEVEL with a precision Alps pot. This also acts as the volume control for the Force. Once the volume is set, your volume is controlled by your main system. Note: When using the Theater Input the volume on the Force is bypassed and will be controlled by your processor.

- Two additional LOWPASS FILTERS A&B, precision Alps pots, allows the user to select any crossover frequency from 35 to 250Hz. These two separate 12db/oct filters provide exceptional control for interfacing the Force in a music system.
- The Force has 0-180 degree PHASE CONTROL: experiment with the phase control. Combined with the input level and lowpass filters A&B switches, the phase switch gives you absolute control over the integration of the Force in your system.
Note: The easiest way to adjust phase is to tune it for maximum output. Since phase is dependent on positioning of the sub relative to the main speakers, adjust phase after you have selected your final placement. The correct phase yields the best overall integration between the main speakers and the Force.
- The Force has stereo highpass outputs. These outputs are actively filtered to rolloff at 12db/octave at 100Hz. You may use these outputs to protect your main speakers from low frequencies. Alternately, you can use the optional passive plug-in high pass filters available from ACI or highpass filtering provided by your Receiver or Processor.
- A limiter and current sensing feedback circuitry protect the driver from being overdriven and reduce distortion.
- The discreet outputs of the amplifier deliver over 250watts RMS to the woofer with extremely low distortion.
- A temperature switch monitors the output devices. In the event of excess heat the switch will shut down the circuitry to prevent damage. Once the heat sinks cool the power will be restored. Because the electronics have been designed and "tuned" to the woofer and cabinet, the Force offers incredible performance in a relatively small cabinet.

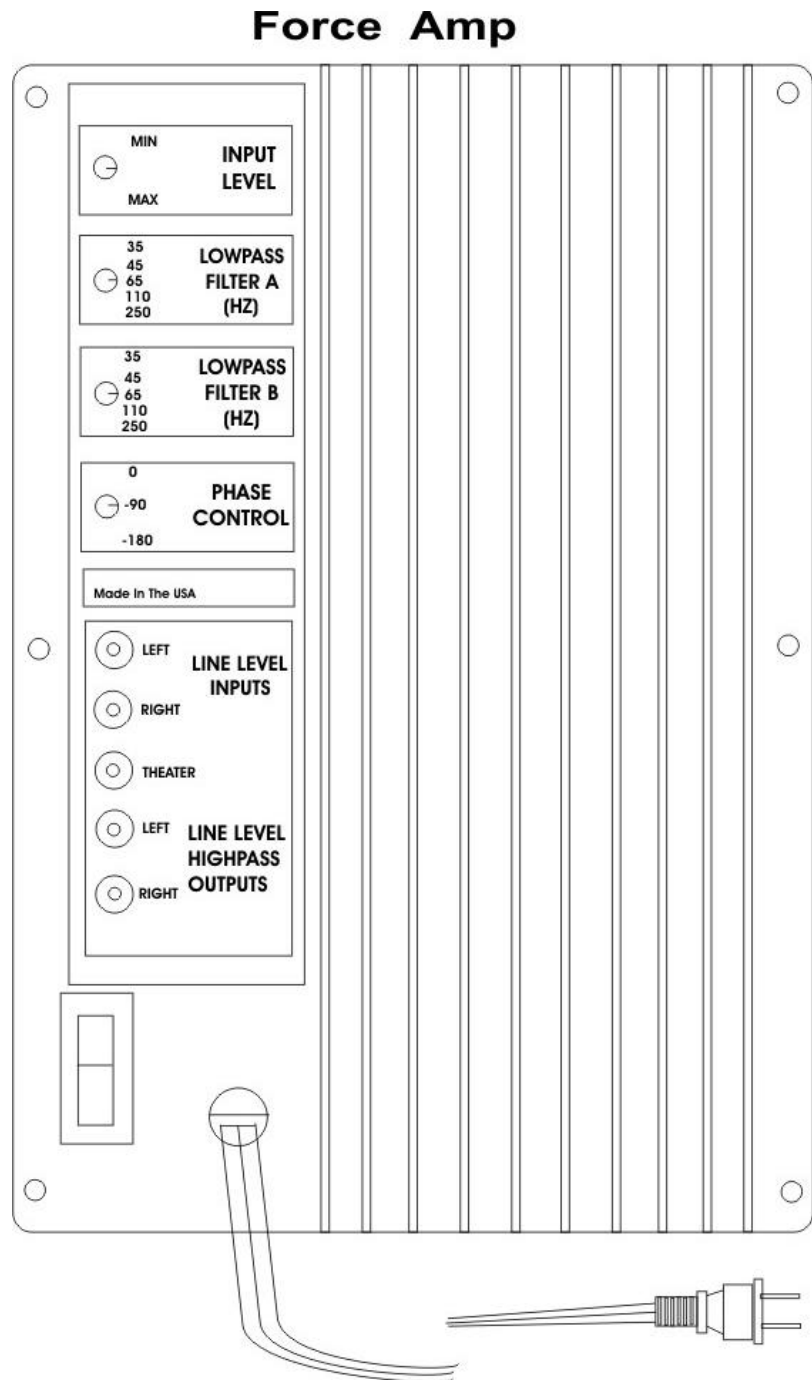

Many subwoofers add unacceptable colorations and actually degrade the performance of otherwise fine speakers. The Force is adaptable for use with virtually any satellite, electrostatic or ribbon speaker. If you are satisfied with your present speakers but just want more bass power and

extension, the Force(s) may be the perfect answer. If you own speakers from manufacturers such as B&W, KEF, Apogee, Quad, Thiel, Magnaplaner, Spica, Celestion, Acoustat, Acoustic Energy, Martin Logan, Wilson, etc., you'll find your listening pleasure greatly enhanced with the Force subwoofers.

Should you have more than one Force?

A single Force provides a major and cost-effective improvement for most people in most rooms with most music. However, there are a number of reasons to consider more than one Force.

-Stereo subwoofers: This is more important if the main speakers used need a rather high crossover frequency. Some very careful listeners may want stereo subwoofers with a crossover as low as 85Hz while many others might be more than happy with a single subwoofer crossed over above 120Hz. *Many of the popular 3 piece satellite subwoofer systems in the \$500-\$1000 range have crossovers above 160Hz! Some listeners can hear the problems immediately while many people never notice the problem.*

-Increase output levels and lower distortion: Some people with large rooms and/or a need for higher than average output levels will want to use more than one Force. For large spaces and/or very high volume requirements any number of Forces can be added to a system. *The Force adds bass power and extension, it takes nothing away from the main system.*

-Get smoother in-room response than with a single subwoofer: In some situations, loading the bass into the room from two or more points can give a better balanced bass throughout the room.

-A third Force may be used for the rear surround channels: The Dolby™ standard calls for a bass roll-off in the rear channels...but Dolby Digital recordings have full-range bass content in the rear channels. Some film lovers feel that having a subwoofer for the rear channel improves impact and realism with such films.

-Multiple Force subs may be stacked to yield higher output: Stacking two Force subs will yield approx. 6db greater output capability than a single sub. A third stacked Force will play 9db louder than a single, and a fourth stacked Force will yield 12db greater output than a single. For those who want very high output levels, adding additional Force units may be far more cost effective than the usual upgrade path of selling and buying new subs.

Installation of the Force(s) in your system:

Placement and Phasing:

-Your Force(s) is a powered subwoofer and will need to be plugged into your household electrical. If you must use an extension cord, select one that is at least 16 gauge thick.

-Getting the optimum performance from your Force(s) is going to require some careful listening. Keep in mind the sound you want. Using test instruments, test CDs, etc. can be helpful but can also be fairly confusing. Low frequency room response testing is a complicated subject and suffice it to say that inexpensive test equipment used without a lot of experience and understanding can give very misleading results. We suggest making your final judgements based on how music *sounds* to you.

- ◇ Placing the Force(s) near your main speakers is the easiest way to get a good match. The ideal placement is often in a corner behind the main speakers, (Diagram A). Placement between the main speakers can also work well.
- ◇ Instead of moving a heavy subwoofer around the room to find the best response there is a simple trick you can use. Place the Force where you normally sit to listen. While playing either test tones or music with a steady bass, walk around the room and listen for the deepest, tightest and smoothest bass response. Move the Force to the place you heard the best bass.
- ◇ Placing the Force(s) close to a wall will increase bass output. Moving the Force(s) into a corner will increase bass output even further. Use the placement to fine-tune the bass your system produces.
- ◇ Placement of the Force(s) will often be determined by your room configuration and furniture layout. Experienced audiophiles know that “fine-tuning” room placement can yield important gains in sound quality. Most listeners will be more than happy with the results they get from the most “convenient” placement. Very serious listeners will want to experiment with various placements to really optimize the match to the main speakers.
- ◇ Correct phase of the subwoofer is dependent on the frequency response of the main speakers and the placement of the subwoofer relative to the main speakers. Correct phase will yield the highest output level at the crossover frequency, (the fullest sound). You may have to re-adjust the crossover frequency and output level.

Placement Diagrams:

Placement A is probably the best solution in most systems. The corner placement provides the highest output level with the lowest distortion from the subwoofer.

Top View of Room **Placement A**

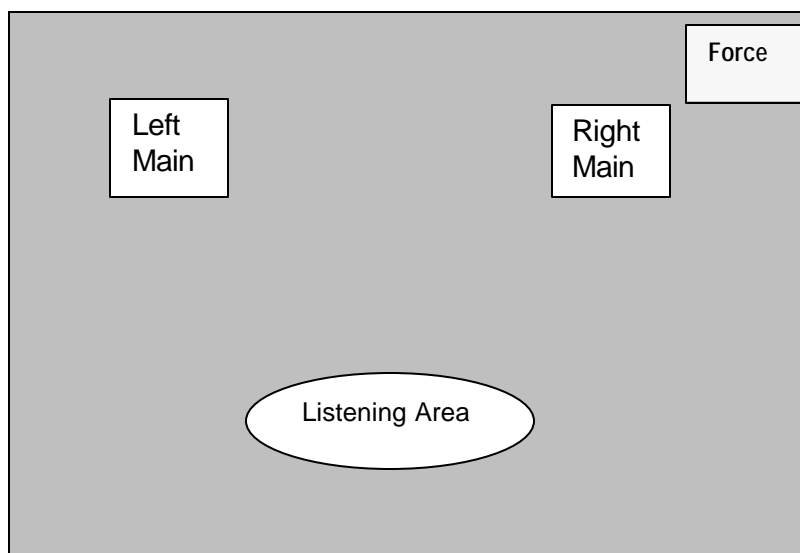

Placement B can work very well. Moving the Force slightly forward of the main speaker may give the smoothest response. Moving the Force back into the corner will produce the greatest amount of bass.

Top View of Room **Placement B**

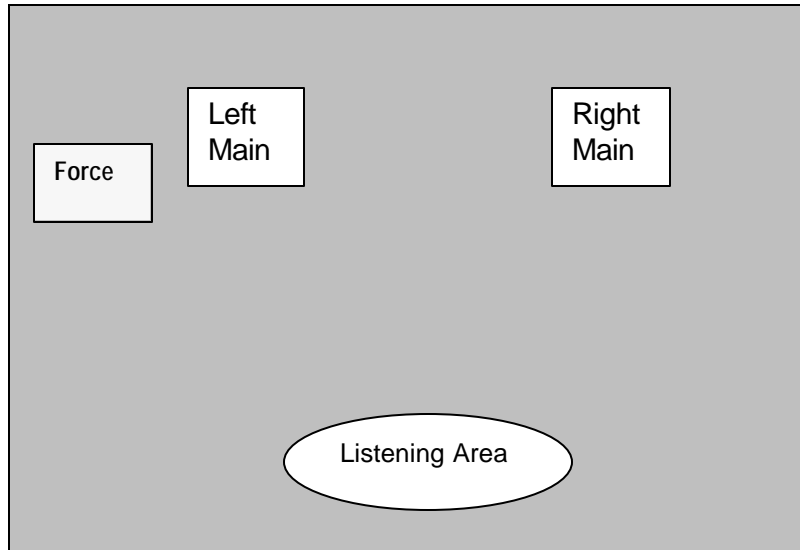

Placement C can sound very good but it will probably require a fairly low crossover. It is also possible to place the Force *behind* the listening position, (not shown). If the Force is far enough behind the listening position and the crossover is low enough you will get very good results.

Top View of Room **Placement C**

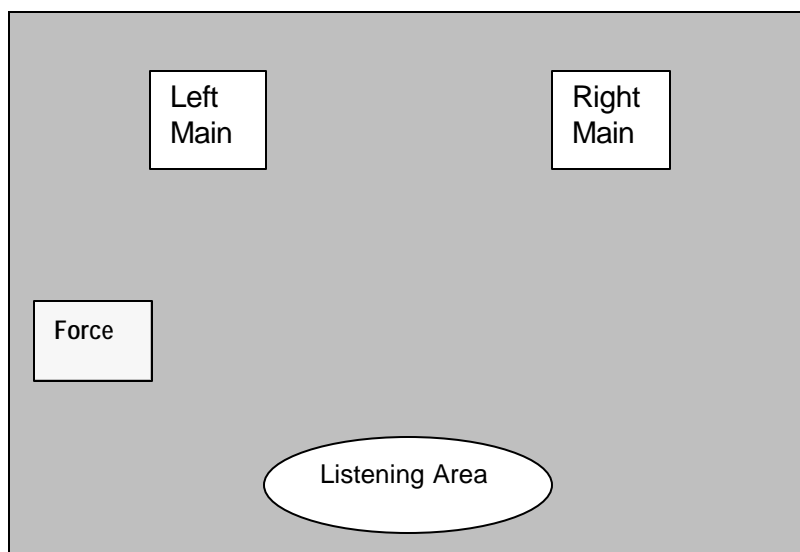

Placement D, Stereo. We can use the distance between the Forces for fine-tuning. Having two Forces right next to each other will yield the highest output level, but spacing them unequal distances from the side walls will give the smoothest room response. The characteristics of your room and your listening tastes will determine which is best for you.

Top View of Room **Placement D** (Stereo)

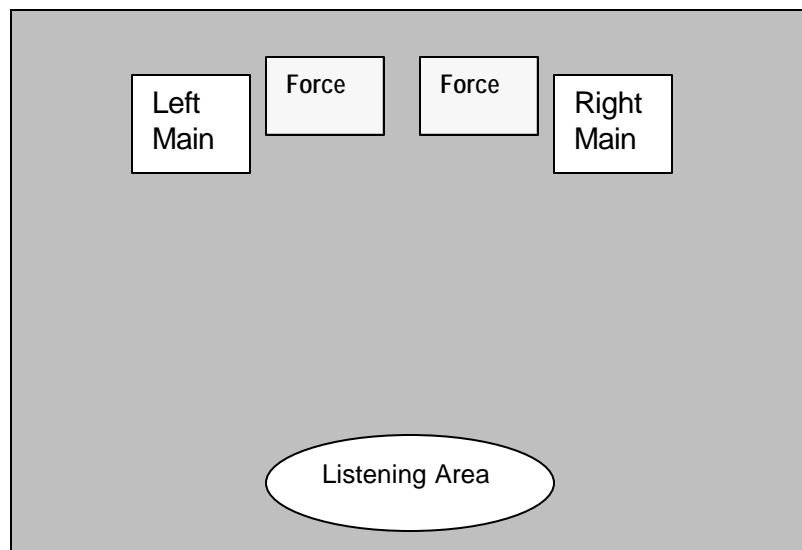

Placement E, Stereo has the potential for the most accurate bass possible. By varying the distances of the two Forces to the corners, sides and front wall you can achieve a very smooth in-room response.

Top View of Room **Placement E** (Stereo)

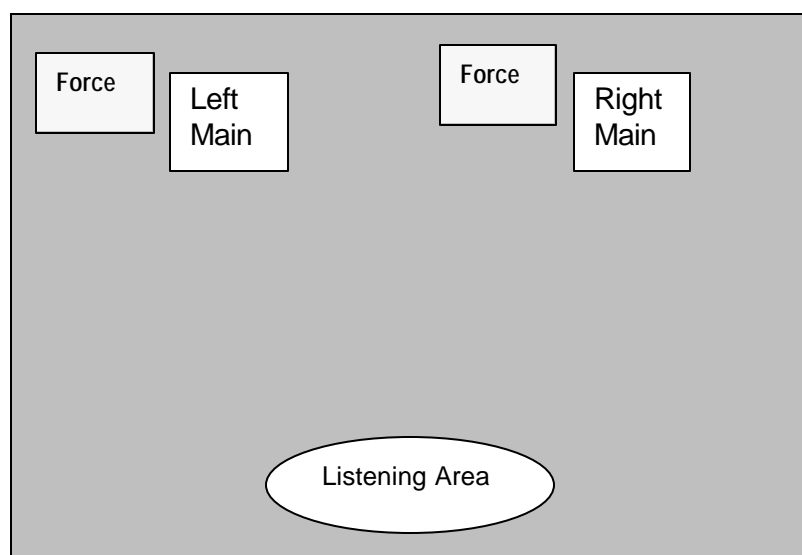

Remember, it is what sounds best to you that counts. Position the speakers to give you the sound *you* want in your room.

Hookup

The Force has three RCA, line-level inputs. Speaker Level Converters are also provided. The rest of your system will determine the input(s) and adapters that you use. We have included some layouts of the most common hookup variations. There are so many types of pre-amps, surround sound receivers and processors that you may need to refer to your owner's manual for specifics.

Speaker Level Converter

Positive to amplifier speaker output



Use one adapter and RCA Interconnect per channel (Left, Right)

Negative to amplifier speaker output

Y Adapter

To Pre-amp output

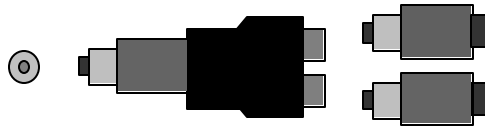

RCA Shielded Interconnect
To Main Amp

Use one adapter per channel (Left, Right)

If your system does not have subwoofer or pre-amp (line-level) outputs you will need to use the Speaker-Level Converters. Connect the *Speaker Level Converters* to the Force Inputs. Hook up your speaker cable from the same output terminals you are using for your main speakers. Connect the speaker cable and the Speaker Level Converters. Connect the same polarity as your main speakers, red to red, black to black. *The high input impedance of the Force will **not** use any power from your receiver or amp.*

Some Hookup Methods Using A Single Force

Using Force High Pass Outputs

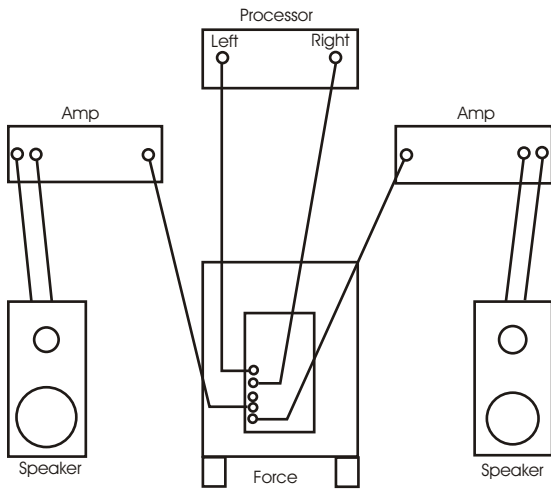

Using The Force with Y-adapters
without Filters

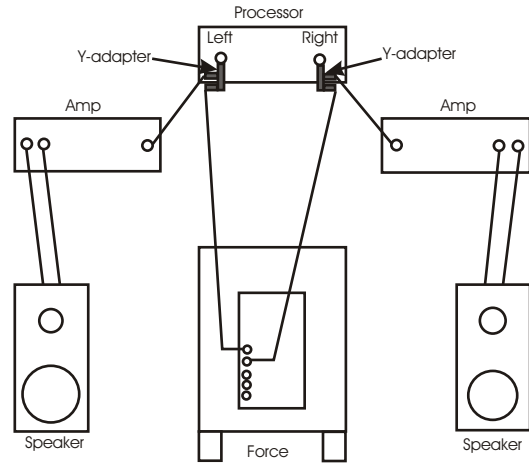

Using The Force with Y-adapters
with ACI High Pass Filters

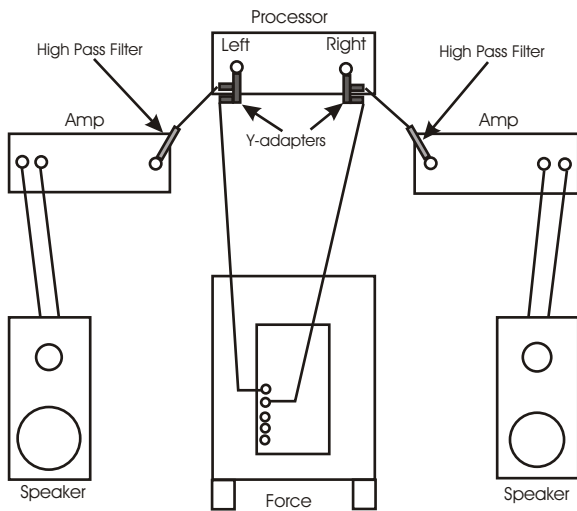

Using The Force Theater Input

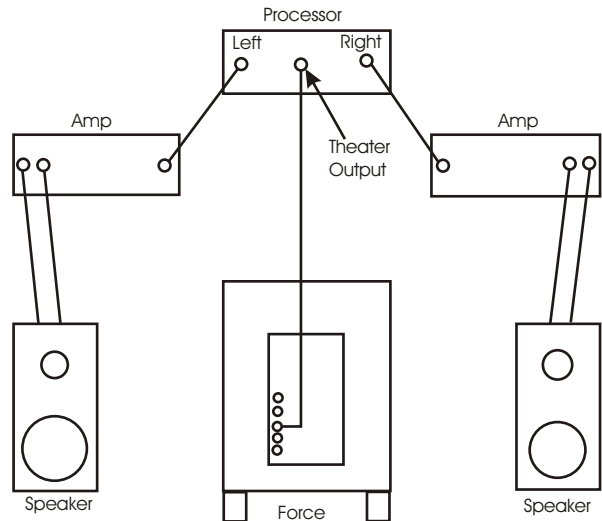

Some Hookup Methods Using Stereo Force Subs

Using The Force High Pass Outputs

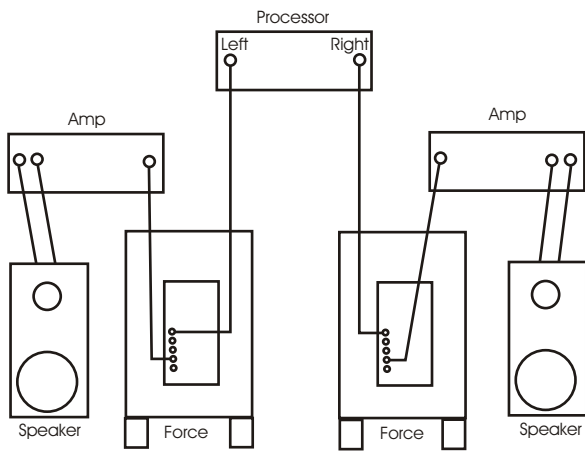

Using The Force with Y-adapters without Filters

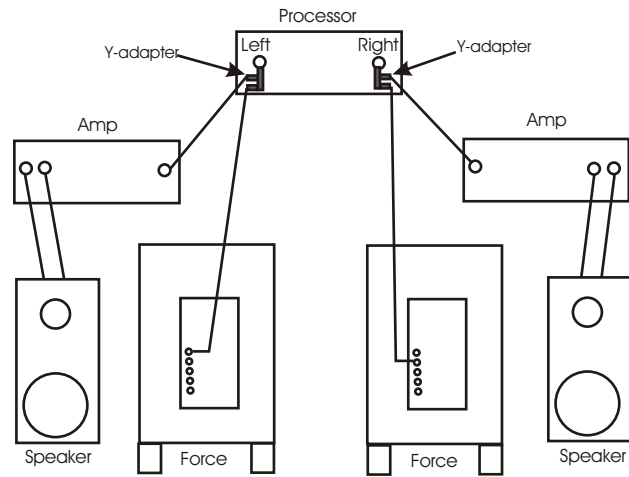

Using The Force with Y-adapters with ACI High Pass Filters

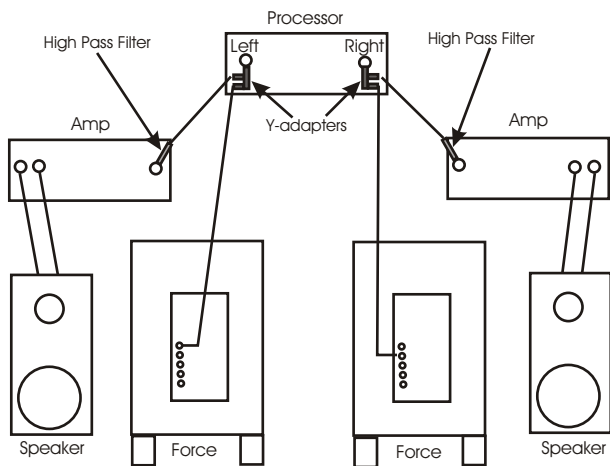

Using The Force Theater Input with a Y-adapter

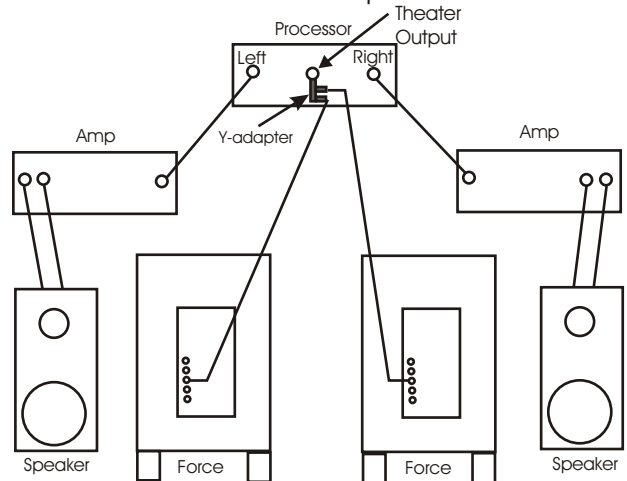

Hookup Methods using a Receiver

Using The Force without Filters and
using Speaker Level Converts

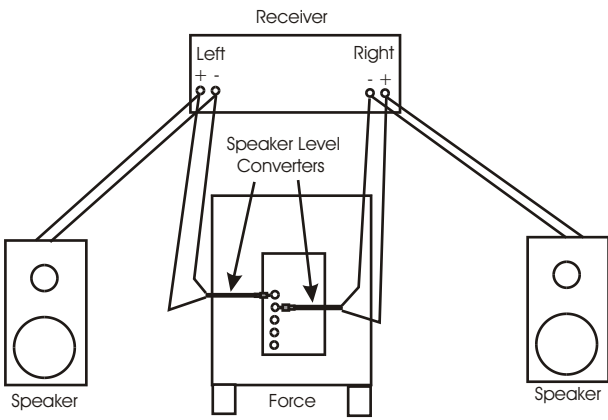

Using The Force with Capacitor Filters
and using Speaker Level Converters

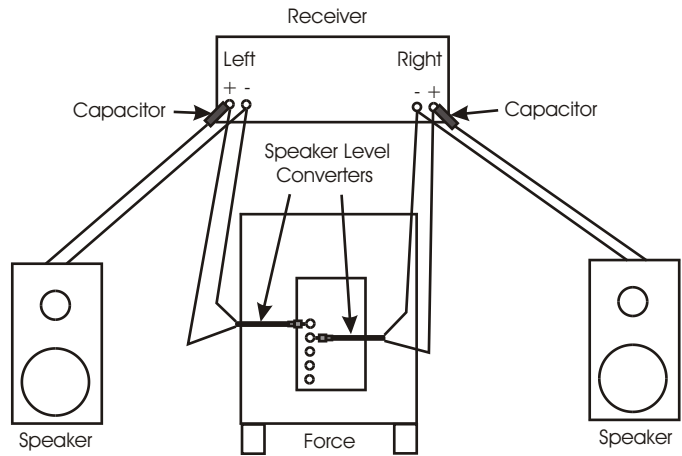

The Force with Preamp outs using
Y-adapters with Capacitors
for Filters

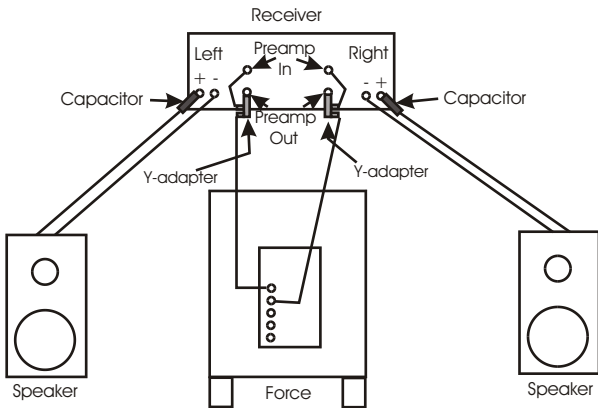

The Force using Theater Input

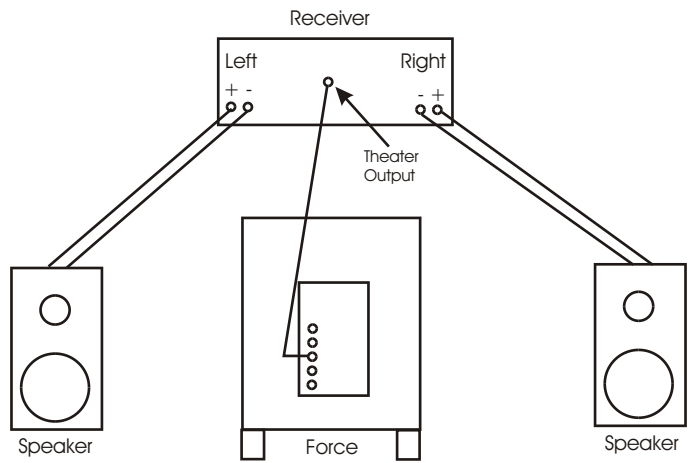

Adjusting the Force(s):

Now that your Force(s) are all connected let's get them playing! First, turn your main system on and switch the Force(s) on.

What we want to do is sum the outputs of the main speakers with the subwoofer(s) for as smooth a transition as possible. The result will be an extended bass response. Many people actually prefer an exaggerated, overly powerful bass. You can easily accomplish this by setting the subwoofer level at a higher than normal level.

For those who want the most accurate and natural bass:

-If you are using a subwoofer output to Theater in connection you will use the bass management features of your receiver or processor. Refer to your owner's manual for details. In this mode you will set the Force crossover frequency dials to 250Hz. Adjust phase to give the highest output level.

For connections other than Theater direct:

-The low-frequency response of your main speakers must be considered. Crossover frequency should be set as low as possible. Lower crossovers will allow the subwoofer to audibly "disappear" and placement is less critical. The deeper your main speakers go, the easier it will be to get a seamless match. *If your main speakers are a ported (vented) design, you will probably get best results with the vent plugged. A cloth or towel will work fine. Just stuff it so that you no longer get air pressure coming from the vent when the speaker is playing.*

-Start with the Force level turned down and both crossover frequencies set to 35Hz. Play music with some solid and deep bass. It's a lot easier to start out with music that has a fairly constant bass. Turn the level up until the low bass fills in naturally. You are looking for bass that goes deeper, not necessarily louder. Experiment with moving the crossover frequency dials upward. At first, move both controls up an equal amount. Move them up until the bass is full, without any missing notes. In some rooms and with some speakers, it may help to adjust crossover B higher in frequency than crossover A. Adjust up or down until the subwoofer best matches the cutoff of your main speakers. The most natural results will be with the lowest crossover point that doesn't leave a "gap" in the response.

Other System Considerations

If the rest of your system does not work properly or is not correctly connected you will not get the best performance from your system. To eliminate problems we recommend the following:

- I. Use the finest associated components you can afford. Turntable, cartridges, pre-amps, amplifiers, (receivers) and cables all have profound impact on the sound of your system. Accurate speakers let more detail through. You will hear more of the beauty of the music, but flaws in your system and/or source material may be more obvious. Any good audio system is made up of matched components. You wouldn't use bargain recap tires on a new Ferrari, and you shouldn't use inferior components with a high quality speaker. Your ACI Force(s) performs like subwoofers costing far more. Keep this in mind when selecting the rest of your system.
- II. Know your source material. People often blame their audio gear for poor recordings. A great number of popular recordings are of inferior sound quality. Unfortunately this applies to records, tapes, DVDs and CDs. There are more good quality recordings available now than just a few years ago, but poor recordings with rolled off low bass,

harsh and constricted mids and highs and little stereo monitor speakers that are grossly inaccurate. Consider that some producers still mix recordings to sound best on cheap table and car radios! This doesn't mean you can't enjoy these recordings, but you should try a few of the best audiophile recordings just to see how terrific your system can be when fed a good signal.

Avoiding Damage

Audio Concepts, Inc. speaker systems are designed for the purpose of accurate reproduction of music in the home. We do our best to make our speakers rugged and reliable. We invested effort in the Force to make it as indestructible as possible. We're happy to say that after producing and selling the Titan Series for years we've yet to have one blown driver returned! Of course there's always Murphy's law! Under certain abusive conditions it may be possible to overdrive the Force. This is possible with your receiver or pre-amp volume control way up with excessively high distorted signal levels.

MORE IMPORTANTLY, as reliable as the Force has been designed, you still need to be careful not to over-drive and damage your main speakers. So please read over the following causes of speaker failure:

Remember, just because you added the power and bass response of the Force, your main speakers won't handle any more power than before.

You can protect your system by following a couple of very simple guidelines:

- A) If it sounds at all distorted, turn it down. Distortion is a warning sign that should not be ignored.
- B) Don't use tone controls or equalizers if possible. IF you must use them, monitor the system carefully.
- C) Beware the party damage epidemic. Speakers are more often damaged during parties. All those bodies soak up sound, requiring more output to sound as loud, bass and treble controls are sometimes cranked up and nobody is listening for distortion.

In over twenty-five years of daily evaluation of all types of speakers on everything from ten to one thousand watts with all kinds of music, we have never damaged a driver without hearing audible distortion. If it sounds bad, turn it down, and you will never damage a speaker.

Speaker Break-in ****Important!!!

Allow at least 60 to 70 hours of playing time before your new ACI Force(s) will sound the best. The adhesives and materials used in manufacturing must stretch and flex properly before a speaker will sound its best. After break-in the bass will be tighter and go lower.

For quicker break-in:

-Play the Force(s) at medium-high volume while away from home. Use music with a lot of low bass content. A CD player on repeat works fine.

Troubleshooting

Occasionally we get a call from someone who feels there is a problem with their ACI speaker. At least a couple of times a year we will get a call or letter that goes something like this: "Speaker not working properly, can't get enough sound even with the volume turned way up." The problem may be different, but with this little information to go on it is almost impossible to trouble shoot the problem "long distance".

The following checklist may help:

- 1) Are all system hookups properly connected, no partial shorted wires, or reversed connections, etc?
- 2) Did you try the rest of your system with other speakers to determine if the problem exists with the speakers?
- 3) Please be realistic in your expectations. Our speakers offer excellent value, but we can't beat the laws of physics. For instance, a medium sized speaker such as the Sapphire sounds excellent but will not play as loudly as a very large speaker.

IF for any reason you aren't satisfied with the sound you're getting from your speakers we want to know about it. **Make sure the speakers have had adequate break-in time.** Before you call or write, please try to narrow down the problem and eliminate other factors. We will need to know:

- ◇ The size of your room
- ◇ Where you have the speakers placed
- ◇ What other equipment is in your system
- ◇ Have you tried other speakers (which ones, and did they eliminate the problem)
- ◇ Any other specific symptoms or information you can provide

Our Customers are #1 with us, and we want you to be completely happy with your ACI speakers!

The Company

Audio Concepts, Inc. (ACI), has been satisfying discerning music lovers since 1977. Our goal has and always will be to provide exceptional product and service to music enthusiasts around the world. Audio Concepts speakers are an expression of dedication to our customers and their desire for accurate musical reproduction. We believe you must audition speakers in your own home and in your own system. Please see the warranty statement for details.

After listening, please fill out and return the warranty registration. This warranty registration is important. It allows us to reach you in the event of future upgrades. The comments you make on the warranty help us to continually improve our products and customer service. Thank You!

Specifications and design are subject to change without notice due to our continuous research and development program.

Handcrafted with pride in the U.S.A.

Audio Concepts, Inc.

901 South 4th Street

La Crosse, WI 54601

Phone: (608) 784-4570 Fax: (608) 784-6367

E-mail: service@audioc.com URL: <http://www.audioc.com>

All rights reserved Audio Concepts, Inc. 2002 04/02

Warranty Registration, Please Return

ACI div. Audio Concepts, Inc.

901 S. 4th Street, La Crosse, WI 54601

service@audioc.com (608) 784-4570

Congratulations on becoming an ACI speaker owner. Completing this registration enables us to contact you regarding future upgrades. Your information helps us provide the best possible products and service. If you need additional room please continue on the back. You may also register your product electronically at our web site. <http://www.audioc.com>

Name: _____

Address: _____

Main reasons you purchased from ACI: _____

Where did you first hear about ACI: _____

System(s) purchased: _____

Date received: _____ Invoice Number: _____

Condition received in: _____

Comments or suggestions regarding our staff or service: _____

Other audio equipment used: _____

Do you have a home-theater system? _____

Do you plan to purchase other speakers within the next two years? _____ If so, what types of speakers are you interested in purchasing, (Tower speakers, satellite speakers, subwoofers, wall speakers, outdoor speakers, home-theater speakers, etc.)

All speakers require at least 60-80 hours of playing time to sound their best. After your speakers have had time to break-in and you've done some serious listening please tell us:

Features you like most about your ACI speakers: _____

Areas of performance or appearance you'd like to change: _____

Other comments or suggestions: _____

Will you recommend us to others? _____ (Over 1/2 of our customers were recommended to us by testimonials on computer data bases or referrals from someone they know. We put the money we save on advertising into the highest quality products at the lowest possible cost to you.)

We would appreciate being able to use your comments in future advertising. Please sign here to allow us that privilege.

Name: _____ Date: _____

Thank you for taking the time to complete and return this registration!