

The Maestro XL Powered Subwoofer

Owner's Manual

Contents:

Guarantee/Warranty	...2
Specifications	...4
Setup	...4
Placement	...7
Hookup: HT	...8
Hookup: Stereo	...10
Other System Considerations	...12
Avoiding Damage	...13
Troubleshooting	...13
Warranty Registration	...15



Audio Concepts, Inc.

571 West Avenue N.

West Salem, WI 54669

Phone: (608) 786-4729 Fax: (608) 786-4710

URL: <http://www.audioc.com> Email: service@audioc.com

All Right Reserved 2008

Sound that Satisfies...Since 1977

Audio Concepts, Inc.

Our Guarantee and Warranty

Satisfaction Guaranteed:

We're sure you're going to love your new Audio Concepts, Inc. (ACI) products! In the unlikely event that you are not satisfied, please contact us within **30 days** of receipt of your ACI products for a hassle-free return.

Simply follow these procedures:

1. **Return Authorization:** Call us at (608) 786-4729 or email service@audioc.com, within 30 days of receipt of your ACI products for a return authorization number. Boldly mark the return authorization number on the outside of the box. Include a brief note stating your name, address and daytime telephone number, along with a short description why the products are being returned.
2. **Returning:** We request that you return the ACI products to us in their original packaging and include packaging materials, manuals, etc. Ship by UPS and insure the products for the invoice purchase price. The customer is responsible for return shipping. *Please note: ACI can not accept C.O.D. returns.*
3. **Credit:** Upon receipt and inspection, we will issue a refund for the invoice purchase price and invoiced UPS Ground service only. Please note this return policy is in effect only if the ACI products are in new condition, in their original packaging, without drilled holes, disassembled or any other modifications.

Speaker Manufacture's Warranty:

For **five years** from receipt, Audio Concepts, Inc. will, at its option, repair or replace factory defective components. (Subwoofer amplifiers are **three years**). This warranty excludes products that have been abused, modified, or disassembled in any way. This warranty does not apply to products, which have been damaged in shipping. Audio Concepts, Inc. liability is limited only to the replacement of defective parts. No other liabilities or obligations are expressed or implied.

The ACI Warranty is fully transferable from the original owner to a secondary owner provided that the original owner notifies ACI, by phone call or by filling out the on-line form:
www.audioc.com/order/warranty_transfer.htm

No warranty will be transferred absent this notification.

Simply follow these procedures:

1. **Return Authorization:** Call us at (608) 786-4729 or email service@audioc.com for a return authorization number. If the warranty repair is during the first year of ownership, additional instructions will be given to you at that time. Boldly mark the return authorization number on the outside of the box. Include a brief note with your name, address and a daytime telephone number, along with a short description why the products are being returned.
2. **Returning:** Carefully repack defective ACI merchandise in their original packaging. Ship via. UPS and insure the products for their full retail value. The customer is responsible for return shipping. Please note: ACI can not accept COD or Freight Collect returns.
3. **Replacement:** Audio Concepts, Inc. will inspect and determine the cause of failure and will pay return shipping on the defective goods replaced or repaired.

Please ship any returns to the following address:

Audio Concepts, Inc., 571 West Avenue N. West Salem, WI 54669 (608) 786-4729

IMPORTANT NOTICE

All new speakers require a minimum of 60 hours break-in-time before they begin to sound the way they are supposed to. A speaker's performance improves significantly once broken in. It is critical that you have at least 60 hours on your speakers before you evaluate them. Don't worry if your speakers do not sound perfect the first time you play them. This is normal until they are broken in. If you are having difficulty getting enough hours on your speakers and your 30 day return privilege is getting near, call us. We will work with you. Please give us the courtesy of breaking the speakers in before you determine they don't sound right.

Many of our customers break their speakers in by:

- A) Leaving them on at moderate listening levels when they are not home.
- B) Leaving them on at moderate listening levels while they sleep.
- C) Running pink noise through them.

These methods are not convenient for everyone and we understand this. But please know that you are not giving yourself, your speakers or us a fair chance if you do not break them in before critical evaluation.

THANK YOU!

The Maestro XL is very heavy. We strongly recommend having two people available to remove from packaging.

The *Maestro XL* Powered Subwoofer

Thank you for your order and congratulations on becoming the owner of an ACI speaker system. The Maestro XL powered subwoofer(s) will provide you with many years of listening pleasure!

ACI's Maestro XL is an extremely powerful subwoofer. Although relatively large, a conventional subwoofer of equal performance would have to be twice the size! The Maestro XL is based on the subwoofer technology of our legendary Titan series. An extreme excursion 15" driver is powered by our proprietary amplification using special circuitry to essentially cut the required box volume in half.

Many subwoofers do a respectable job with explosions, shotguns, and crashes. The market is loaded with black boxes and tubes that beg to be "hidden". The Maestro XL is different. Reasonably sized and attractively built to compliment your fine furniture. A number of fine wood finish choices are available. The Maestro XL goes way loud, and it goes way deep. **Warning:** *ACI is not responsible for any tickets you may receive for noise violations or domestic disturbance!* More importantly, it will allow a seamless and completely transparent blend with your main speakers. Your sound stage will be enhanced, not degraded. Instruments like acoustic and electric bass, piano, and percussion will come through with vivid realism. The Titan and Force have earned a reputation of being some of the most musical subs available at any price. The Maestro XL continues this tradition of musical excellence in an extreme output configuration.

The internal enclosure is constructed of 1" non-resonant high-density fiberboard with extensive internal bracing. The mounting for the down-firing woofer is 2" thick for additional resonance control and stability. Satin black durable finish, cherry veneer, or piano gloss black available.

Many subwoofers add unacceptable colorations and actually degrade the performance of otherwise fine speakers. The Maestro XL is adaptable for use with virtually any satellite, electrostatic or ribbon speaker. If you are satisfied with your present speakers but just want more bass power and extension, the Maestro XL(s) may be the perfect answer. If you own speakers from manufacturers such as B&W, KEF, Aerial, Quad, Thiel, Magnaplaner, Revel, Thiel, Martin Logan, Wilson, etc., you'll find your listening pleasure greatly enhanced with the Maestro XL subwoofers.

Specifications

Frequency Response: 19-120Hz, ± 3 db, system Q < .6

Crossover: Adjustable Low-Pass: 35-250 24db/octave

Sensitivity: Adjustable

Dimensions: 21 3/4" tall, 21 3/4" wide and 21 3/4" deep

Weight: Sub 112 lbs, Amp 24 lbs

Amplifier Dimensions: Fits standard 19" Rack Mount, Width: 17 1/4" w/o brackets, 19" with brackets, Height: 3 3/8", Depth: 18 3/8"

Special Circuitry: Protection Circuitry, Woofer Behavior Control

Woofer: (downward firing) Proprietary 15", cast-frame, ultra long throw woofer

Rec. RMS Power: Separate rack-mountable amp delivers 500 watts RMS < .5% THD distortion.

Maestro XL Subwoofer Setup

Integrating a sub is a process that requires following ordered steps. You'll find it easy in some rooms/systems, and very time consuming in others. The key is to eliminate each variable one at a time. We

include a setup disc, free with purchase of our subs. Use of the setup CD is optional. Please refer to the attached directions for the test CD.

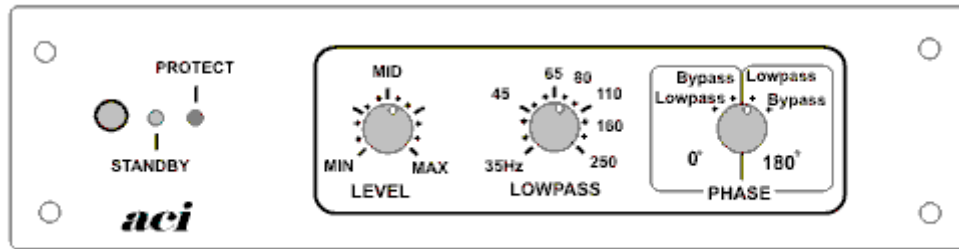

MAESTRO AMP - FRONT CONTROL PANEL

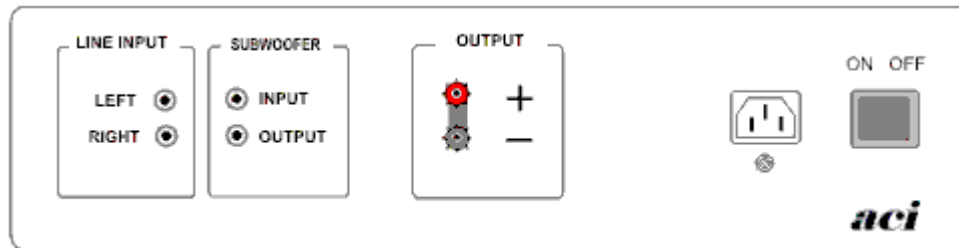

MAESTRO AMP - BACK CONTROL PANEL

The front panel controls of the *Maestro XL* perform the following functions:

Faceplate: The Maestro XL amplifier is shipped with a cosmetic faceplate installed. This faceplate needs to be removed to make the setup adjustments. An allen wrench is supplied to remove the four bolts that hold the faceplate in place. Once setup is completed you may re-install the faceplate for a finished appearance and to keep un-authorized fingers from upsetting your adjustments. The amplifier is also supplied with brackets and hardware for optional installation into standard 19" racks.

Run / Standby Switch: This push button switch is used to toggle the amps operating mode between Run and Standby. The Standby mode mutes the outputs and the amp is in idle and virtually no current is drawing from the AC lines.

Run / Standby Indicator LED: When the BLUE LED on the front panel is ON, it indicates the amp is in Run mode. When the BLUE LED is OFF and the Protect LED is **RED**, it indicates the amp is in Standby (Mute) mode.

Power-on / Fault Indicator LED: When the unit is in Run mode, (normal operation) the GREEN LED indicates normal operation. If the unit is in Run mode, and the GREEN LED turns RED, it indicates that an over-temperature or fault condition exists. In the event of a RED LED during normal operation, simply switch the amp to Standby for a few minutes until the amp has cooled off, and it should be ready to resume normal operation again.

Level: This controls the volume of the Maestro XL. The volume needs to be set at the same volume as your main speakers to get a seamless blend.

Lowpass / Crossover Control: Adjusts the frequency response of the Maestro XL. A 24dB/oct Linkwitz-Riley filter is adjustable from 35Hz to 250Hz.

Phase / Crossover Switch: A four position switch used to change output phase from 0 deg to 180 deg and to enable or bypass the crossover function.

- Position 1: 0 deg phase shift, lowpass crossover enabled
- Position 2: 0 deg phase shift, lowpass crossover bypassed
- Position 3: 180 deg phase shift, lowpass crossover enabled
- Position 4: 180 deg phase shift, lowpass crossover bypassed

The rear panel connections and controls of the *Maestro XL* perform the following functions:

On/Off Switch: Used to turn the amp on and off. Normally amp is left on all the time. When not playing, it draws about the same amount of power as a nightlight.

Power Cord: The cord is detachable and can be plugged into any standard 3 prong outlet.

Left & Right Line Level Inputs: These inputs accept line-level signals from an external source. Use either or both of these inputs. They are internally mixed together by the amplifier's input circuitry and applied to the lowpass filter, level, and phase.

Sub Line Level Input: The primary purpose of this input is to simplify running multiple Maestro XL amps together in a daisy chain hookup. The signal is buffered and passed directly to the sub output jack without any processing, then to the input circuitry and applied to the lowpass filter, level, and phase.

Sub Line Level Output: Use to directly connect (daisy chain) multiple Maestro XL amps without loss of signal level. This signal is a buffered output of the summed Left, Right and Sub inputs. The full-range signals from the line level inputs are presented at this output, no signal conditioning, or filtering is done to this signal. The level, crossover, and phase control have no effect on the gain of this output.

Speaker Level Outputs: (see diagram below) The speaker level amp outputs are for connecting to the Maestro XL subwoofer enclosure inputs with a single length of speaker cable. Mount the amplifier near your source components for easy access to the front panel adjustments.

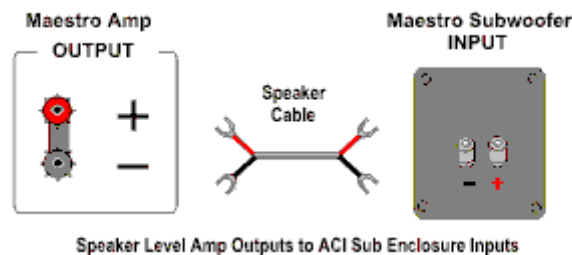

Miscellaneous:

- Sophisticated circuitry protects the driver from being overdriven and reduces distortion.
- The ICE amplifier modules deliver over 500watts RMS to the woofer with extremely low distortion.
- Bulletproof design for high output levels without worry.
- A temperature switch monitors the output devices. In the event of excess heat the switch will shut down the circuitry to prevent damage. Once cooled the power will be restored.
- The Maestro XL offers incredible performance in a relatively small cabinet because the electronics have been designed and "tuned" to the woofer and cabinet.

Speakers Level Adapter



Two of these are supplied with each Maestro XL subwoofer. The Speaker Level Adapter converts an amplified, (speaker level), signal to the line level signal required by the subwoofer. Not required for line-level hookup. The adapters may be installed directly in parallel with your main speakers. This can be done at the speaker outputs on your receiver or amplifier. Alternately you may put these in parallel with your speaker at your speakers input terminals. You may attach any type of speaker cables to the speaker cable end using either electricians twist nuts or a twisted, soldered and wrapped connection. *If running shielded interconnects to sub, you will need to purchase RCA Female - Female adapters.*

Y-Adapter



Used to split a line level output into dual outputs. Use with shielded RCA interconnects. For example; use Y-Adapters at pre-amp outputs to get dual outputs. One set of outputs goes to the subwoofer(s), one set of outputs goes to the main amplifier inputs.

RCA Female-Female Adapter



Used to join two shielded RCA interconnects. May also be used to join the ACI Speaker Level Adapter to any RCA shielded interconnect.

Step One: Initial Placement

Determine initial placement of the sub. This is often a matter of "where it will fit" in the room. You will also need to plug the Maestro XL amp into a 120-volt wall receptacle. The Maestro XL is supplied with a power cord. If this is not long enough, you may replace or use a suitable extension cord. Three of the best places to put your Maestro XL:

1. Place the sub in one of the corners behind the main speakers. A corner placement behind the main speakers usually yields the deepest, cleanest bass. As long as the subwoofer is correctly adjusted it will not be boomy or overbearing. The sub doesn't have to be placed "tightly" in the corner, just as near as possible.
2. Place the sub near the wall, behind the main speakers. Approximately 1/3 of the width of the room is often ideal.
3. Place the sub along one of the sidewalls. Approximately 1/3 of the length of the room is often ideal.

If you have the flexibility to try different placements, we'd encourage you to do so. Every room is different. Experimentation is the best way to find the best placement. One trick is to place your subwoofer in your normal listening position. Listen or take measurements from your subwoofer placement options to find the ideal position. For example, if your two options are the left front corner and somewhere along the right sidewall, you'll listen and or take measurements at these two positions.

Step Two: Hookup and Adjustment

The Maestro XL subwoofer may be integrated into virtually any quality audio or audio-video system. First you must determine your hookup scheme. Select from the choices below and then make adjustments.

There are essentially two types of hookup and adjustment:

1. **Home Theater (5.1 - 7.1 systems)** Systems with a subwoofer output on your receiver or processor

OR

2. **Stereo (two-channel)** Systems without subwoofer output

Home Theater - Hookup

This approach requires a shielded RCA interconnect cable from the subwoofer output on your receiver or processor to one of the inputs on your Maestro XL amplifier.

- Choose either the Left or Right input. You will be setting the crossover to bypass and using the bass management of your receiver or processor. There are currently many different bass-management schemes depending on brand and model of receiver, pre-amp or processor. You will most likely set all your main speakers to "small" although it is a good idea to experiment with these settings. Your receiver, pre-amp or processor controls subwoofer volume after initially being set on the amp.
- The sub input can also be used and is available to aid in daisy chaining multiple subs. If you wish to use multiple subs for higher output levels simply daisy chain the sub amplifiers together using the subwoofer outputs on the Maestro XL amp.

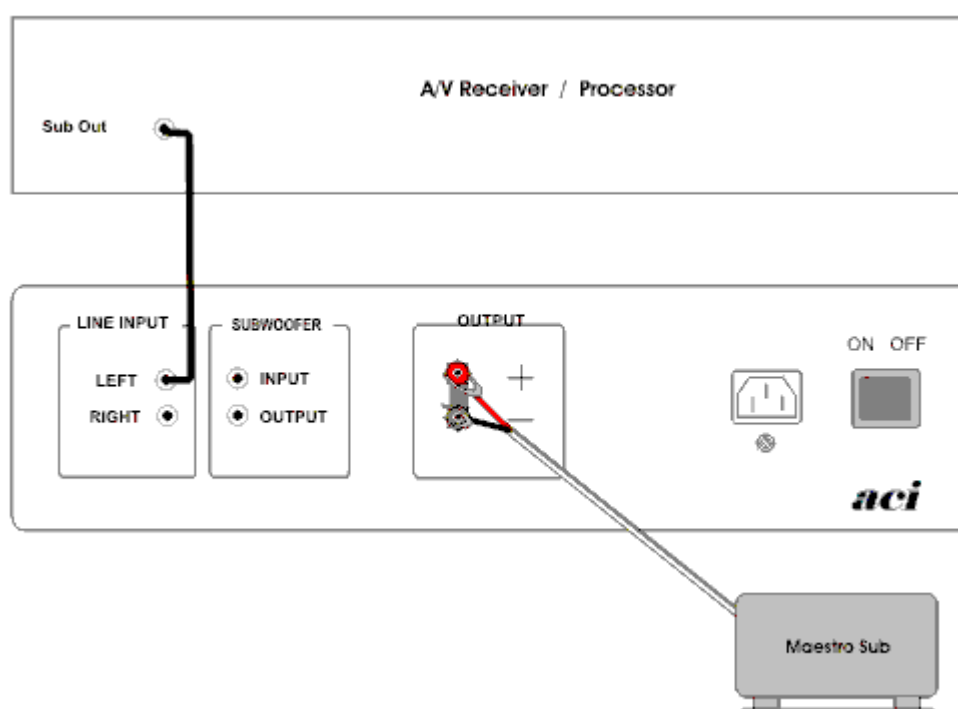

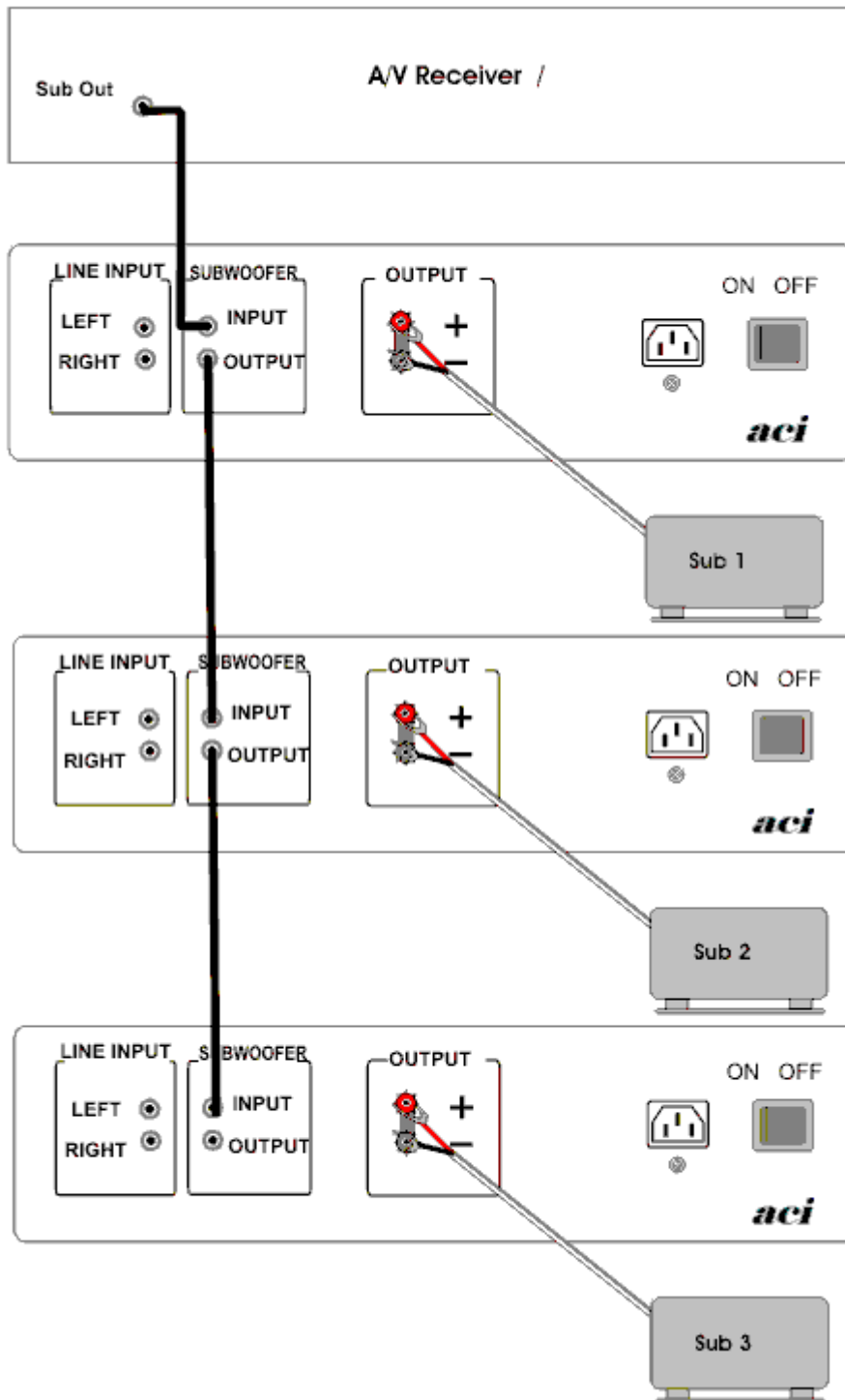

Home Theater - Adjustments

Adjusting the Maestro XL for Home Theater:

1. **Lowpass crossover frequency** doesn't matter, it will be bypassed and controlled by your processor.
2. **Set phase** to Bypass and 0 degree. Then use the test CD to determine whether phase should be at 0 or 180 degrees. (Please refer to the test CD procedures for this)
3. **Input level** is adjusted both on the Maestro XL amp and from your processor. Start with the Maestro XL level about ½ way and adjust up or down as needed.

Stereo (Two-Channel) - Hookup

First you must determine your hookup scheme. Your choice of hookup will be determined by the capabilities of the rest of your system. The Maestro XL has RCA, line-level inputs and Speaker Level Converters are also provided for speaker level connection. Select from the following and then make adjustments:

A) Two Channel Systems that do **NOT** have preamp outputs:

1. Hookup with Speaker Cable using Speaker Level Converters

This is sometimes referred to as "bass augmentation". The main speakers are run full-range and the subwoofer is used to augment or fill in just the lower bass. Connect a second set of speaker cables in parallel with your existing speaker cables. This set of cables is run to our speaker level converters, which plug into the subwoofer left and right inputs. (If using stereo subs you will run one cable to each sub). Set crossover, the input level, and phase control to get a seamless blend with your main speakers.

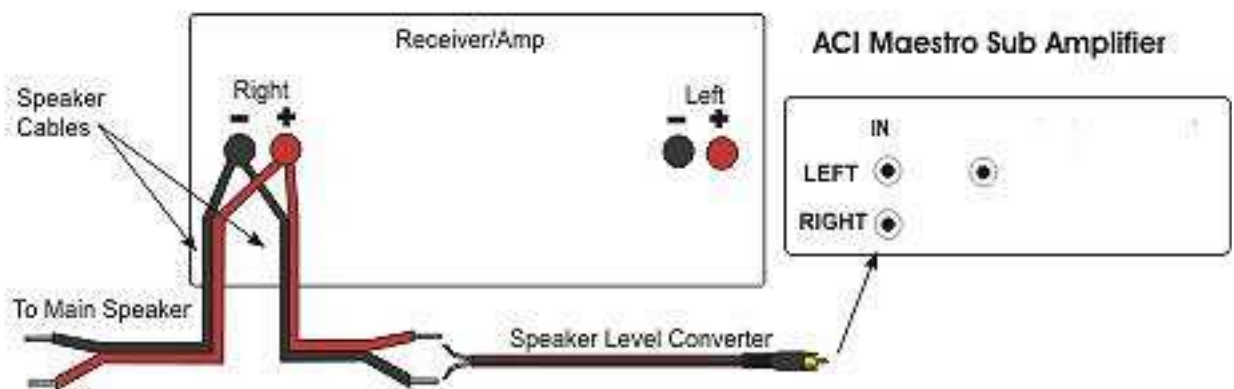

* **Note:** Only one channel shown

2. Hookup with Shielded Interconnect using Speaker Level Converters

Connect speaker level converters in parallel with your main speakers. Connect a female to female RCA adapter to the speaker level converter and use shielded RCA interconnect cables to connect to the subwoofer. (If using stereo subs you will run one interconnect to each sub). (DH Labs Subsonic Cable is perfect for this application.)

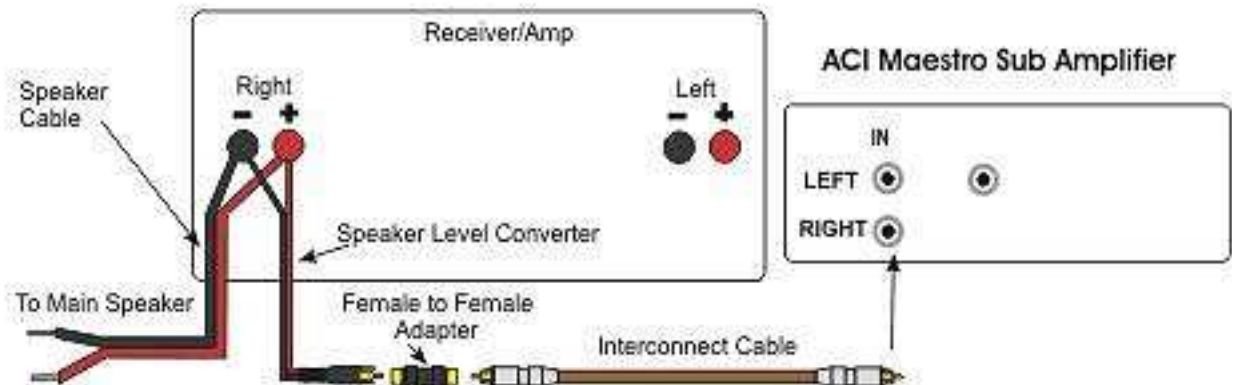

* **Note:** Only one channel shown

B) Two Channel Systems that DO have preamp outputs:

1. Separates or Integrated Amp with Preamp outputs & Main amp inputs

Use Y-Adapters to split the signals from the left and right preamp outputs. Connect one end of each Y-Adapter to left or right main amp input, (using RCA interconnect). Use proper lengths of shielded interconnects to connect the other ends of the Y-Adapters to the right & left inputs on the sub. (If using stereo subs you will run one interconnect to each sub).

Your main speakers will receive a full range signal. To reduce low frequency content to your main amp and speakers, use optional High Pass Filters plugged into the main amp inputs.

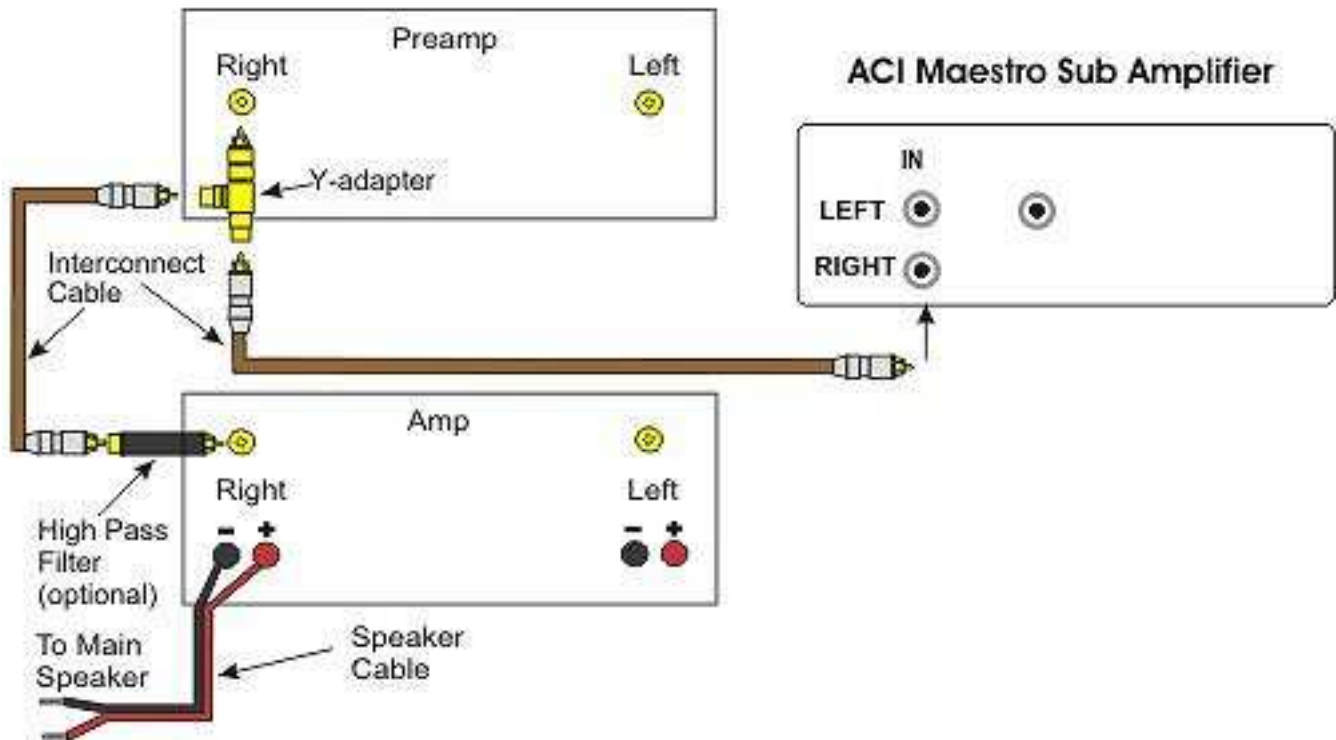

*Note: Only one channel shown

Stereo (Two-Channel) - Adjustments

Adjusting the Maestro XL for Stereo:

1. **Set Initial Adjustments:** Crossover frequency: 80Hz, Phase: 0 degrees with lowpass, Level: $\frac{1}{2}$ way
2. **Adjust Phase:** Adjust volume level so sub is audible with an 80Hz test tone from the included test CD. Switch between 0 and 180 degrees to find maximum output at the listening position. This is most easily accomplished with an extra person to work the switch / control. If using an SPL meter such as the Radio Shack, it might be easier to track the change with the 80Hz Warble tone rather than the 80Hz Sinewave.
3. **Adjust Level:** Start with input level all the way down and set crossover frequency filter to 35Hz. As you play music with a repetitious bass line, adjust the input level upward until it is just consistently audible. The low bass should fill in naturally. You are looking for bass that goes deeper, not necessarily louder.
4. **Adjust Crossover Frequency:** With the frequency filter at 35Hz, gradually adjust upward until the bass seems full, without any missing notes, and then back off just a bit. Adjust up or down until the subwoofer best matches the cutoff of your main speakers. The most natural results will be with the lowest crossover point that doesn't leave a "gap" in the response. Lower crossovers will allow the subwoofer to audibly "disappear" and placement is less critical.
5. **Fine-tune:** Sit back and listen with a variety of music. Make any changes one at a time to fully assess the effect. Take your time!

Troubleshooting Setup and additional considerations

- **If** you try to use the sub to adjust for recordings that lack bass you'll go nuts, adjust the sub to well recorded music and leave it alone. You'll never get it perfect for all music because the music isn't recorded consistently!
- **If** the music seems to lack warmth, try adjusting the frequency control up just a bit at a time. Too much, and the sub becomes easily audible by itself.
- **If** your main speakers have ports (vents) try stuffing them; this sometimes improves the transition drastically. The ports can easily be stuffed with cloth. *Just stuff it so that you no longer get air pressure coming from the vent when the speaker is playing.* Stuffing the port changes the response from fourth order to second order and yields a more gradual rolloff in the main speakers. It can make all the difference in the world!
- **If** you have a problem with hum there are generally three possible causes:
 1. **Ground loops or power issues** are the most common cause of subwoofer hum. Turn everything off and remove all connections from the Maestro XL amp to the rest of the system. Turn the Maestro XL amp back on. If the hum is gone, the problem was probably caused by a ground loop. In this case, you will need to either use a "cheater" plug on the power cord, or use a GLE (Ground Loop Eliminator), available from Radio Shack. If the hum is still there, plug the Maestro XL amp into an outlet on a different house circuit. If the hum is gone, it might be a matter of the subwoofer picking up interference from something in the house electrical system such as fan speed control or light dimmer. Use a different outlet. If the hum remains, continue to step #2.
 2. **Poor connections or RCA interconnects** can cause hum. If you move the shielded cable that connects the Maestro XL amp to your system and you hear a change in the hum it is likely you have poor shielding or a defective RCA plug. Replace the cable.
 3. **Amplifier damage** is the least likely cause of hum. However, if you have ruled out ground loops, power issues, or a defective connecting cable, it is possible that there is a problem with the Maestro XL amp. Contact ACI service for assistance.

Other System Considerations

If the rest of your system does not work properly or is not correctly connected you will not get the best performance from your system. To eliminate problems we recommend the following:

- I. Use the finest associated components you can afford. CD and DVD players, turntable, cartridges, pre-amps, amplifiers, (receivers) and cables all have profound impact on the sound of your system. Accurate speakers let more detail through. You will hear more of the beauty of the music, but flaws in your system and/or source material may be more obvious. Any good audio system is made up of matched components. You wouldn't use bargain recap tires on a new Ferrari, and you shouldn't use inferior components with a high quality speaker. Your ACI Maestro XL(s) performs like subwoofers costing far more. Keep this in mind when selecting the rest of your system.
- II. Know your source material. People often blame their audio gear for poor recordings. A great number of popular recordings are of inferior sound quality. Unfortunately this applies to records, tapes, DVDs and CDs. There are more good quality recordings available now than just a few years ago, but poor recordings with rolled off low bass, harsh and constricted mids and highs and little stereo monitor speakers that are grossly inaccurate. Consider that some producers still mix recordings to sound best on cheap table and car radios! This doesn't mean you can't enjoy these recordings, but you should try a few of the best audiophile recordings just to see how terrific your system can be when fed a good signal.

Avoiding Damage

Audio Concepts, Inc. speaker systems are designed for the purpose of accurate reproduction of music in the home. We do our best to make our speakers rugged and reliable. We invested effort in the Maestro XL to make it as indestructible as possible. We're happy to say that after producing and selling the Titan Series for years we've yet to have one blown driver returned! Of course there's always Murphy's law! Under certain abusive conditions it may be possible to overdrive the Maestro XL. This is possible with your receiver or pre-amp volume control way up with excessively high distorted signal levels.

MORE IMPORTANTLY, as reliable as the Maestro XL has been designed, you still need to be careful not to over-drive and damage your main speakers. So please read over the following causes of speaker failure:

Remember, just because you added the power and bass response of the Maestro XL, your main speakers won't handle any more power than before.

You can protect your system by following a couple of very simple guidelines:

- A) If it sounds at all distorted, turn it down. Distortion is a warning sign that should not be ignored.
- B) Don't use tone controls or equalizers if possible. IF you must use them, monitor the system carefully.
- C) Beware the party damage epidemic. Speakers are more often damaged during parties. All those bodies soak up sound, requiring more output to sound as loud, bass and treble controls are sometimes cranked up and nobody is listening for distortion.

In over twenty-nine years of daily evaluation of all types of speakers on everything from ten to one thousand watts with all kinds of music, we have never damaged a driver without hearing audible distortion. If it sounds bad, turn it down, and you will never damage a speaker.

Speaker Break-in ******Important!!!**

Allow at least 60 to 70 hours of playing time before your new ACI Maestro XL(s) will sound the best. The adhesives and materials used in manufacturing must stretch and flex properly before a speaker will sound its best. After break-in the bass will be tighter and go lower.

For quicker break-in:

-Play the Maestro XL(s) at medium-high volume while away from home. Use music with a lot of low bass content. A CD or DVD player on repeat works fine.

Troubleshooting

Occasionally we get a call from someone who feels there is a problem with their ACI speaker. At least a couple of times a year we will get a call or letter that goes something like this: "Speaker not working properly, can't get enough sound even with the volume turned way up." The problem may be different, but with this little information to go on it is almost impossible to trouble shoot the problem "long distance".

The following checklist may help:

- 1) Are all system hookups properly connected, no partial shorted wires, or reversed connections, etc?
- 2) Did you try the rest of your system with other speakers to determine if the problem exists with the speakers?
- 3) Please be realistic in your expectations. Our speakers offer excellent value, but we can't beat the laws of physics. For instance, a medium sized speaker such as the Sapphire sounds excellent but will not play as loudly as a very large speaker.

IF for any reason you aren't satisfied with the sound you're getting from your speakers we want to know about it. **Make sure the speakers have had adequate break-in time.** Before you call or write, please try to narrow down the problem and eliminate other factors. We will need to know:

- ◇ The size of your room
- ◇ Where you have the speakers placed
- ◇ What other equipment is in your system
- ◇ Have you tried other speakers (which ones, and did they eliminate the problem)
- ◇ Any other specific symptoms or information you can provide

Our Customers are #1 with us, and we want you to be completely happy with your ACI speakers!

The Company

Audio Concepts, Inc. (ACI), has been satisfying discerning music lovers since 1977. Our goal has and always will be to provide exceptional product and service to music enthusiasts around the world. Audio Concepts speakers are an expression of dedication to our customers and their desire for accurate musical reproduction. We believe you must audition speakers in your own home and in your own system. Please see the warranty statement for details.

After listening, please fill out and return the warranty registration. This warranty registration is important. It allows us to reach you in the event of future upgrades. The comments you make on the warranty help us to continually improve our products and customer service. Thank You!

Specifications and design are subject to change without notice due to our continuous research and development program.

Audio Concepts, Inc.

571 West Avenue N.
West Salem, WI 54669

Phone: (608) 786-4729 Fax: (608) 786-4710

E-mail: service@audioc.com Web: www.audioc.com

All rights reserved Audio Concepts, Inc. 2008 rev 03/08

Warranty Registration, Please Return

ACI div. Audio Concepts, Inc.

571 West Avenue N. West Salem, WI 54669

service@audioc.com (608) 786-4729

Congratulations on becoming an ACI speaker owner. Completing this registration enables us to contact you regarding future upgrades. Your information helps us provide the best possible products and service. If you need additional room please continue on the back. You may also register your product electronically at our web site. /www.audioc.com

Name: _____

Address: _____

Main reasons you purchased from ACI: _____

Where did you first hear about ACI: _____

System(s) purchased: _____

Date received: _____ Invoice Number: _____

Condition received in: _____

Comments or suggestions regarding our staff or service: _____

Other audio equipment used: _____

Do you have a home-theater system? _____

Do you plan to purchase other speakers within the next two years? _____ If so, what types of speakers are you interested in purchasing, (Tower speakers, satellite speakers, subwoofers, wall speakers, outdoor speakers, home-theater speakers, etc.)

All speakers require at least 60-80 hours of playing time to sound their best. After your speakers have had time to break-in and you've done some serious listening please tell us:

Features you like most about your ACI speakers: _____

Areas of performance or appearance you'd like to change: _____

Other comments or suggestions: _____

Will you recommend us to others? _____ (Over 1/2 of our customers were recommended to us by testimonials on computer data bases or referrals from someone they know. We put the money we save on advertising into the highest quality products at the lowest possible cost to you.)

We would appreciate being able to use your comments in future advertising. Please sign here to allow us that privilege.

Name: _____ Date: _____

Thank you for taking the time to complete and return this registration!